

Tube & Pipe Mill

Ornamental Stainless Steel Tubes

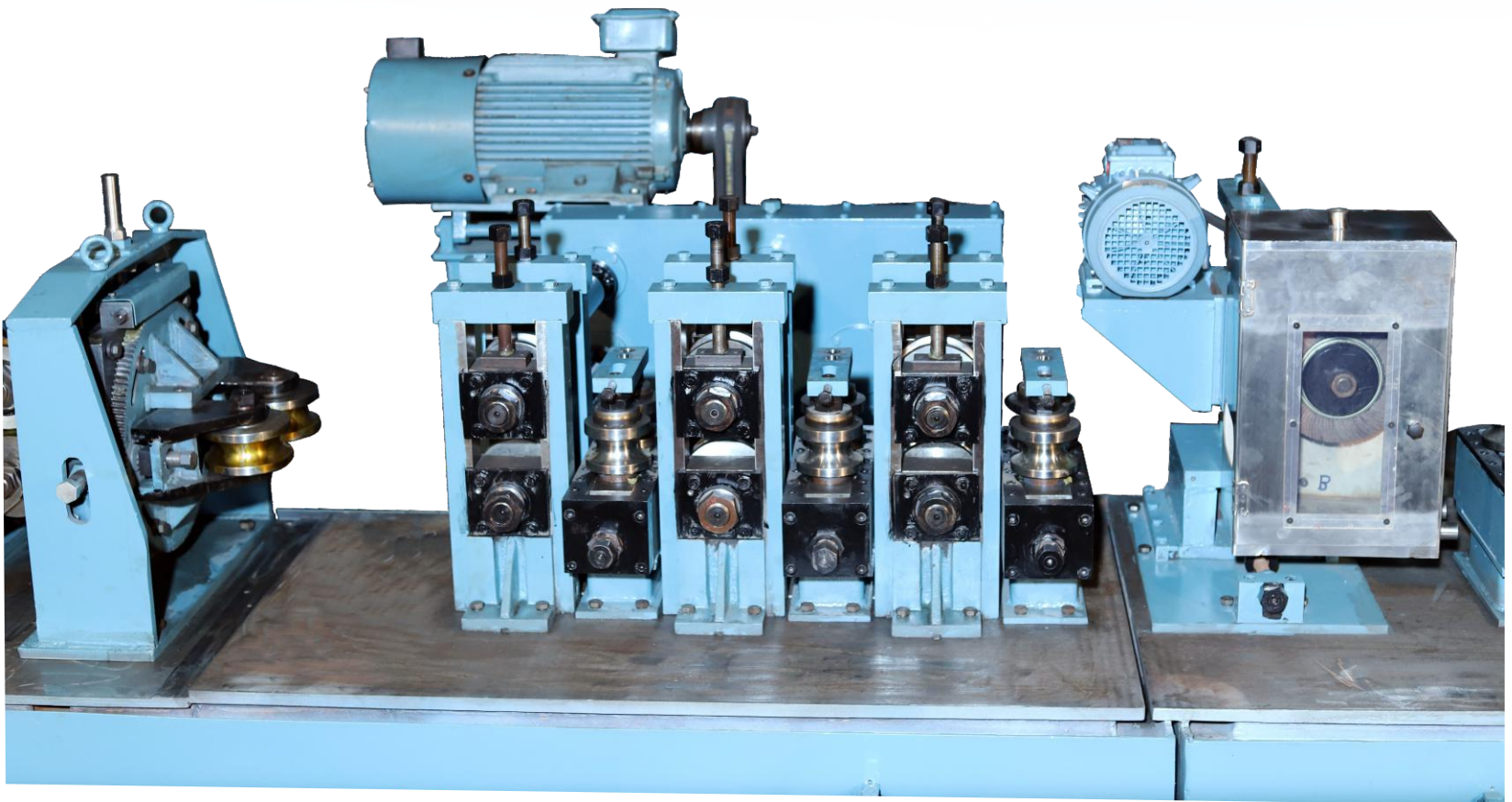

Parth

EQUIPMENT LTD.

MANUFACTURER OF TUBE MILL
AND ALLIED MACHINERIES



**T M SHAH
GROUP**

Tube & Pipe Mill Features

- Tube mills for various grades of stainless steel
- Over 300 Installation in India and Abroad
- Economical Tube Mills specially designed for Ornamental Stainless Steel tubes
- Emphasis on : Material selection,
Manufacturing and Process selection
Dimensional and Geometrical accuracy
- Cross key ways for permanent alignment for forming and sizing stands on the base frames
- Heat treated and Ground Shafts
- Screw down movement of Turk's head rolls by link pin mechanism for ease in reforming thick walled sections
- W-forming system in Roll design for better edge-forming & freedom from wrinkle while forming sizes with adverse t/D ratio
- Duly heat treated & ground Rolls from High Carbon High Chromium (HCHC), finished on CNC turning machine
- Compact Design for effortless forming of thin walled tubes

Tooling



TUBE MILL FOR S.S. TUBES

Model No.	Tube Size Range*		Tube Thickness*	
	Min O.D.	Max O.D.	Min.	Max.
PARTH 30 LTM	8	32	0.4	1.6
PARTH 50 LTM	12	51	0.5	2.0
PARTH 75 LTM	19	76	0.6	2.5
PARTH 100 LTM	25	100	0.8	2.5

*All dimensions are in mm.

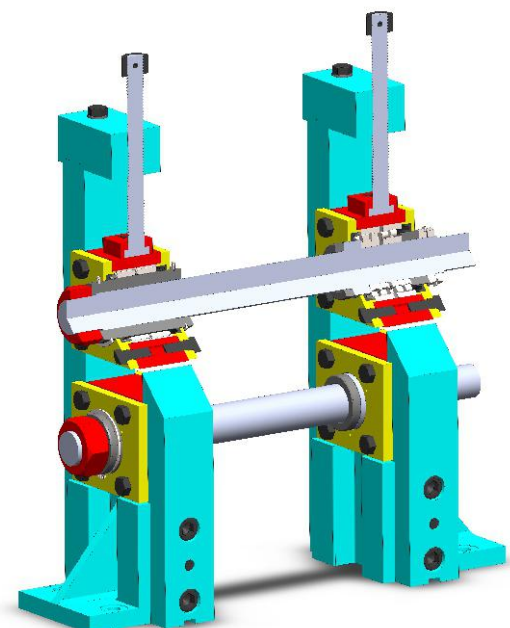

Parth
EQUIPMENT LTD.

4209-9, 4223-25, Phase IV, GIDC Estate, Vatva, Ahmedabad - 382 445. (Gujarat) India.

Phone : +91 94276 16352, 94267 20511

E-mail : ntshah@pathequipment.com • www.parthtubemill.com